

油輪空氣管頭 AIR PIPE HEAD TANK

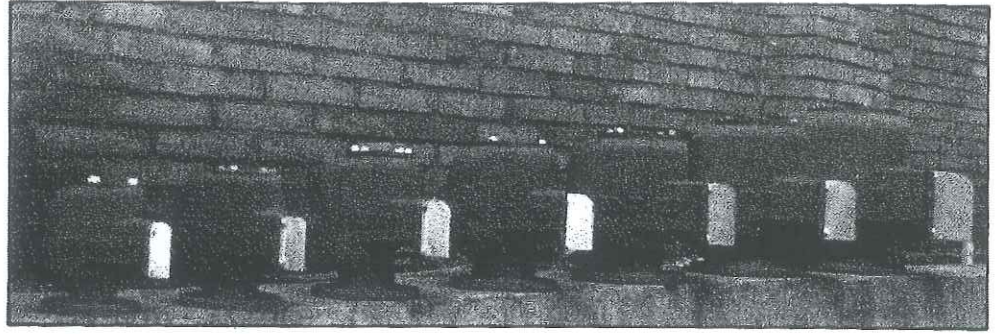

尺寸表 DIMENSION TABLE

SPE.	d	L1	L2	L3	H	h	h1	h2	W	w	t	T	WEIGHT kg	SETS/W
50	50	75	103	75	180	120	115	50	17	135	6.5	12	6.5	63
65	65	85	120	85	210	139	130	60	22	155	6.5	12	9.2	63
80	80	90	153	100	245	160	150	70	27	190	7.5	14	17	45
100	100	110	160	110	270	179	169	75	35	225	8	16	24	30
125	125	130	195	130	310	204	194	80	44	265	8	16	31	16
150	150	155	225	150	355	223	212	90	53	300	9	18	48	12
200	200	200	295	180	440	275	264	100	70	400	9	20	67	8

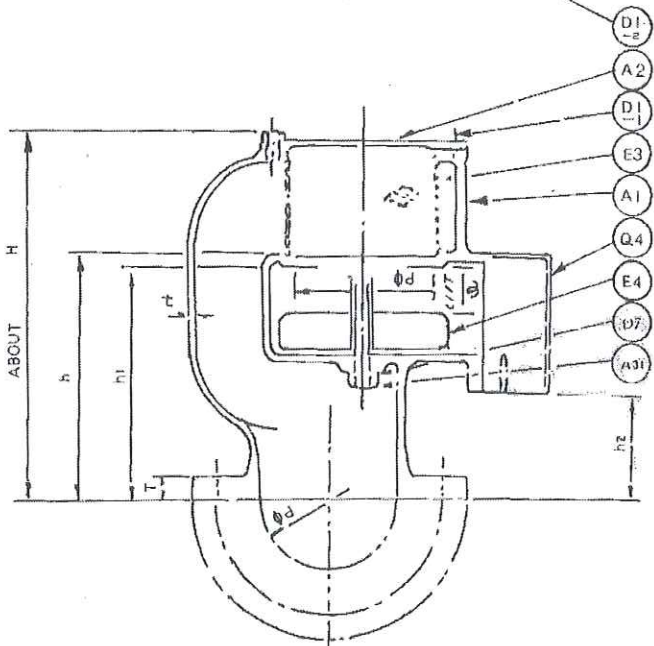
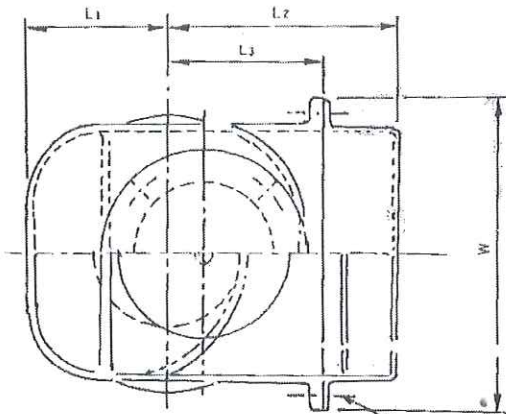

零件表 SERVICE CONDITION

Q4	H000	STL. STEEL	SUS 304	1	
E4	FLOAT	STL. STEEL	SUS 304	1	
E3	SCREEN	STL. STEEL	SUS 304	1	30M3P#
D7	SPRING WASHER	STL. STEEL	SUS 304	1	
D1-2	BOLT	STEEL	SS41		GALV.
D1-1	BOLT	STL. STEEL	SUS 304		
A31	STAY	BRASS	C3104	1	
A2	COVER	GRAY IRON	Z200-400	1	
A1	BOOY	GRAY IRON	Z200-400	1	
MARK	PARTICULARS	MATERIAL		QUANT	RE-MARKS

